

DATASHEET

S01.01.02.055_ AMPERE-7

ARCHITECTURE LIGHT LENS:

IESNA 7° beam.

AMPERE SERIES, TIR-lens (Ø35 mm) ,also available to assembled with holder (Ø37mm).

General Information

Lens Material	: PMMA
Size	: D37 mm
typ.FWHM	: 7°
Design LED	: CREE XPE
Compatibility	: 3030/3535/5050
typ.Efficiency	: 93%
Fasten	: Glue/Pin
IP class	: N/A
Zhaga	: NO
RoHS	: YES
Color	: Clear



产品图 Product drawing

版本 REV	日期 DATE	变更内容 CHANGE (ITEM)
A0	2021-6-10	新建 NEW

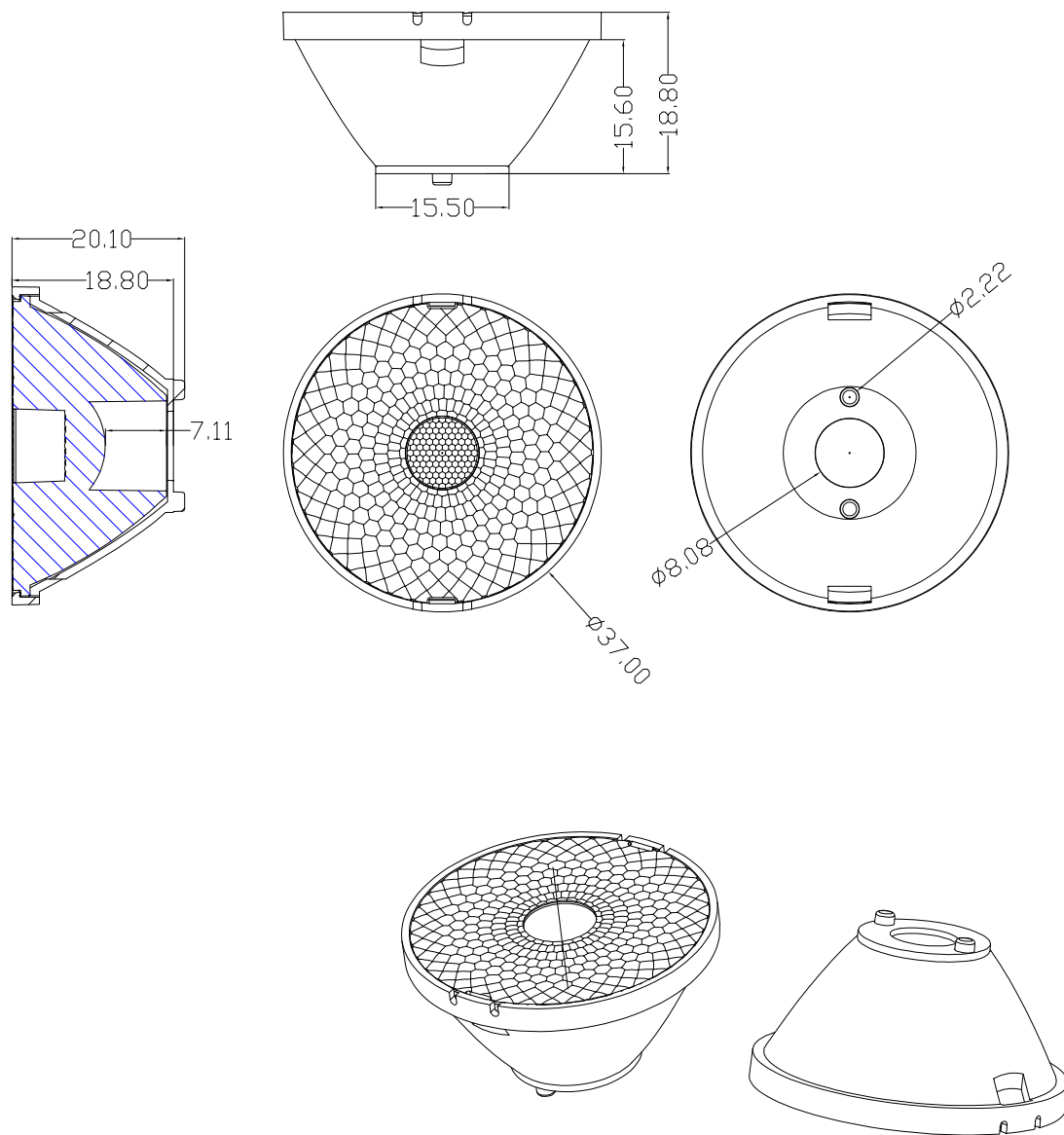

技术要求:

1. 图中有序号尺寸需要重点控制;
2. 产品不得有缺胶、气泡、收缩、黑点等异常;
3. 未标注公差尺寸参考GB/T14486公差表

Technical requirements:

- 1.The size of the ordered number in the figure needs to be controlled;
- 2.The product shall not have lack of glue, bubbles, shrinkage, black spots and other abnormalities;
- 3.Dimensions with unmarked tolerances refer to GB/T14486 tolerance table.

产品名称 Item name	S01.01.02.055_ AMPERE-7	产品材质 Product material	PMMA
图法 View	 第三视角	设计 Designed	Yvan
比例 Scale	1:1	审核 Checked	Haiqiu
单位 Unit	MM	批核 Approved	

SUNLUMIN OPTICS CO.,LTD

OPTICAL RESULTS

1) PHOTOMETRIC DATA(MEASURED):



LED model	CREE XPE
Light colour	White
LEDs/each optic	1
FWHM	H7.2°,V7.2°
FWTM	H14.4°,V14.3°
Required components:	

N/A

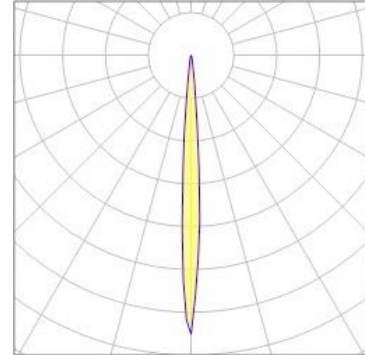

Usage and Maintenance

1) Due to varying asymmetric chip locations, especially on mid-power LEDs, the exact source of light is not always located at the centre of the LED packet. SunLumin recommends rotating such LEDs on the PCB in a regular pattern for smoother results.

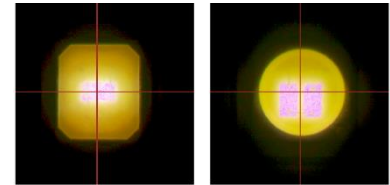

Sample layout proposal:

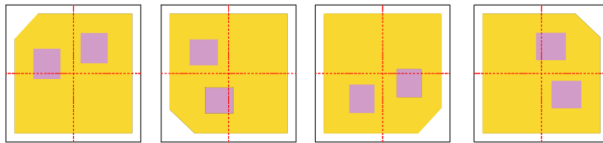

Example A

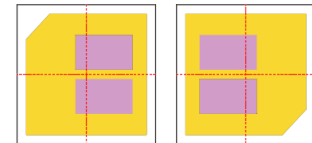

Example B

- 2) If necessary, clean lenses with mild soap, water and soft cloth.
- 3) Never use any commercial cleaning solvents on lenses, like alcohol.
- 4) Please handle lens with wearing gloves, skin oils may damage lens or its optical characteristic.

Disclaimer

When gule pass through holes, columns and other structures, or part of the thin structure, will form a weld line. Please note that flow lines and weld lines on the external surfaces of the lenses are acceptable if the optical performance of the lens is within the specifications.

The typical beam angle will be changed by different color, chip size and chip position tolerance. The typical total beam angle is the full angle measured where the luminous intensity is half of the peak value. The chart data is for reference only. Please test the data again before using

The appearance and specifications of the product can be changed to improve the quality and/or performance without notice.

SunLumin assumes no liability of any kind for the possible deviation from any provided data or any other damage resulting from the usage of the provided data.

Last update: 30-Apr-25